

# HAGON





This catalogue is a guide to our wide range of frames, parts and equipment, but our stocks are so extensive that it is only possible to show a small selection. If the items you require are not shown just telephone or write — we probably have what you require.

## SERVICES

**WORKSHOP FACILITIES:-** Alloy welding, Rebores, Helicoils, Crank repairs, Valve seat inserts, Fork straightening, Beadblasting, One off parts made.

**MATERIALS:-** Alloy plate and sheet, Alloy rods and bars, Steel tubes T45, 531, CDS2, Aircraft and seamless, Mild steel tubes, High tensile bolts, nuts and studding.

## POSTAL SERVICE

Fast Cash on Delivery service by telephone or by return post is our speciality. Parcels weighing up to 20 Kilos (44lb) can be sent by GPO to your door. We can send any number of separate parcels and even complete machines can be sent in kit form.

Charges at GPO rates. Parcels over 20 Kilos in weight can be sent by Roadline or Securicor.

## EXPORT

We can send goods to any part of the world, either by post or shipping agents, by air or surface. Items up to 20 Kilos (44lb) can be sent by post. In many countries we can send goods COD., but where no COD service is available please send cash with order, plus postage. Prices quoted do not include postage.

## CONDITIONS OF SALE

**SPECIFICATIONS.** In order that we may continually probe the future, to increase the performance of our products, we must reserve the right to vary specifications.

**PRICES.** Whilst we make every attempt to keep price lists current, inevitably some prices must vary, all goods will be charged at prices ruling at time of despatch.

**GUARANTEE.** ALL products used in racing applications are considered expendable and we reserve the right to refuse any claims made on such items. We will, however, evaluate any claim individually and sympathetically.

PLEASE QUOTE PAGE AND REFERENCE NUMBER WHEN ORDERING /



## ALF HAGON PRODUCTS LTD.

350/2 HIGH ROAD, LEYTON  
LONDON E10 6QQ ENGLAND

TELEPHONE 01-539 8416 - 01-556 9200 - 01-556 4447



Superb handling and low weight have made the Hagon LTR an outright winner on long and grass tracks throughout the world. Chassis are available to accept every popular engine/gearbox or engine unit with centre or side carb. Rolling chassis complete **REF. 301**

**SPECIFICATION LTR.**

Wheelbase	57" (1448mm)
Seat height	30½" (775mm)
Head angle	70°
Weight with	
<b>WESLAKE ENGINE</b>	193 lbs (88kgs)
Ground clearance	5¼" (133mm)
Front suspension travel	4¾" (121mm)
Rear suspension travel	4¾" (108mm)
Fuel capacity	5 pints (3 litres)
Oil capacity	1 pint (.6 litres)

**HAGON LTR FRAME ASSEMBLY**

Comprising:- Main diamond frame, Dural engine plates, Swinging arm, Pivot, Girling units, Nuts and bolts, etc.

**REF. 302**

**HAGON LTR FRAME KIT**

Comprising:- Main diamond frame, Swinging arm, pivot, Girling Units, High tensile bolts, Mudguards, Seat with brackets, Fuel tank complete with taps and fixing bolts, Forks complete with spindle and head bolt, Engine and Gearbox plates.

**REF. 303**

*SUSPENSION TRAVEL given is for air suspension but band forks and girling rear units are also suitable for the LTR.*





The most successful track racing machine ever, the Hagon SANDRACER is available for side carb engines (Mk2) and centre carb engines (Mk3) both types share the same geometry and specifications.

## SPECIFICATIONS

Wheelbase	137-147cm 54"-58"	Ground Clearance	13cm 5"
Seat Height	74cm 29"	Front Suspension Travel	10cm 4"
Head Angle	70°	Rear Suspension Travel	9cm 3½"
Weight	89kgs. 195lbs.	Fuel Capacity	3 Litres (5 pints)
Front Wheel	23"	Oil Capacity	.6 Litres (1 Pint)
Rear Wheel	19" or 22"	Finish	Nickel

**WORLD  
LONG TRACK  
CHAMPIONSHIP  
WINNER  
1978, 1979  
AND 1980**

Available for most engine/gearbox combinations, the Hagon Sandracer is supplied in the following forms:-

As shown, but without engine, transmission or brakes For side carb engines (Mk2) **REF. 401**

For centre carb engines (Mk3) **REF. 402**

## Sandracer Kit

Comprising — Main diamond frame, Sub-frame, Swinging arm, Pivot, Girling Units, High tensile bolts, Fibreglass mudguards, Seat with brackets, Fuel tank complete with taps and fixing bolts, Forks complete with spindle and head bolt, Engine and Gearbox plates.

For side carb engines (Mk2) **REF. 403**

For centre carb engines (Mk3) **REF. 404**

## Sandracer Frame Assembly

Comprising — Main diamond frame, Sub-frame, Dural engine plates, Swinging arm, Pivot, Girling units, Nuts and bolts, etc.

For side carb engines (Mk2) **REF. 405**

For centre carb engines (Mk3) **REF. 406**



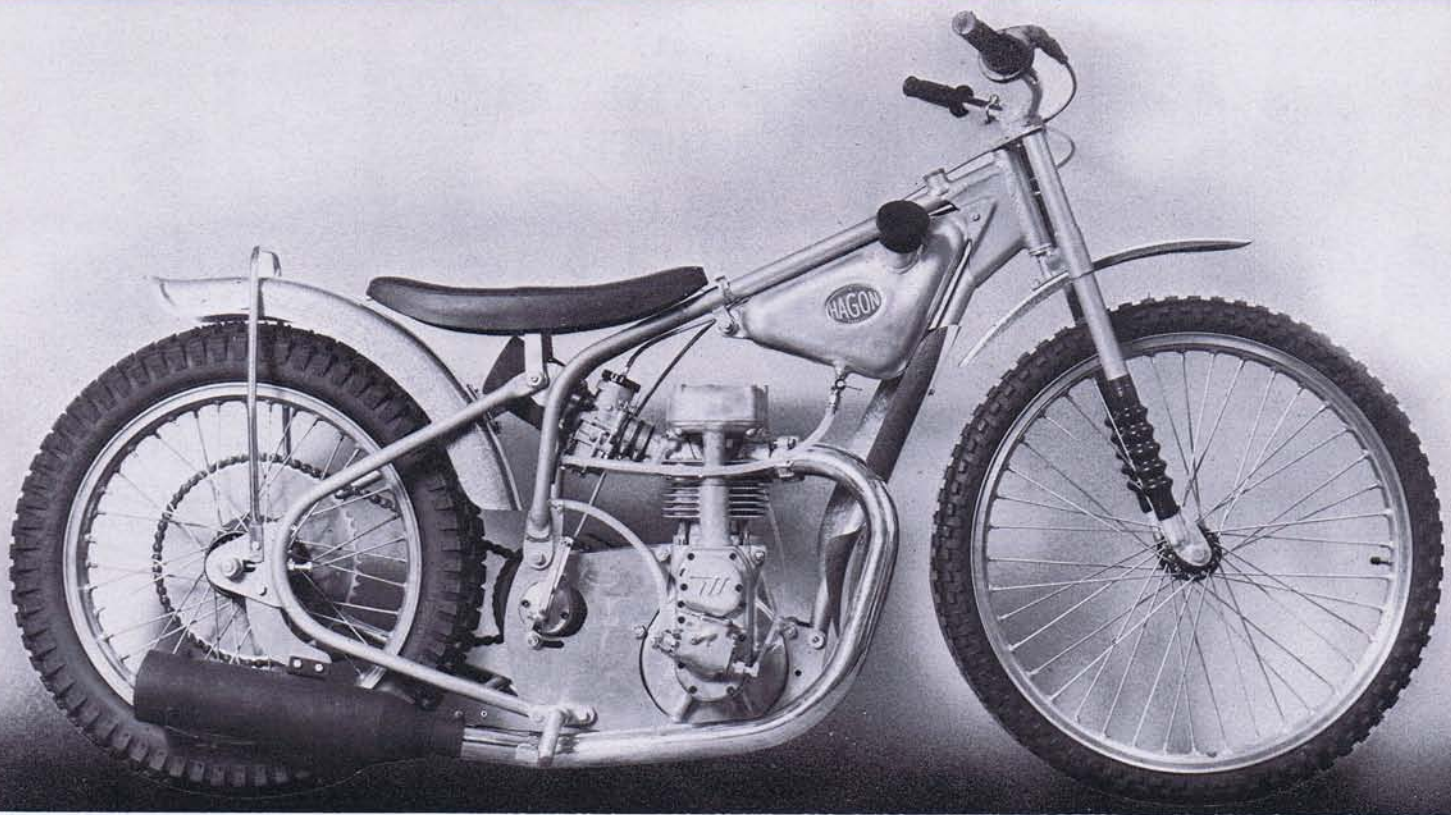

**HAGON SPEEDWAY FRAMES** are available for centre or side carburettor engines and are made to interchange with Jawa frame components.

**HAGON SPEEDWAY CHASSIS** Complete less engine and transmission for Centre carb. engines. **REF. 501**

Wheelbase	132cm (52")
Ground clearance	10cm (4")
Weight (with Weslake engine)	77Kgs. (170 lbs)
Fuel capacity	3 Litres (5 Pints)
Oil capacity	.6 Litre (1 Pint)
Steering head angle	72°
Seat height	71cm (28")

**SPEEDWAY FORKS**

2" movement with internal springs 4½" between fork blades, hammer grey enamel finish, complete. **REF. 502**

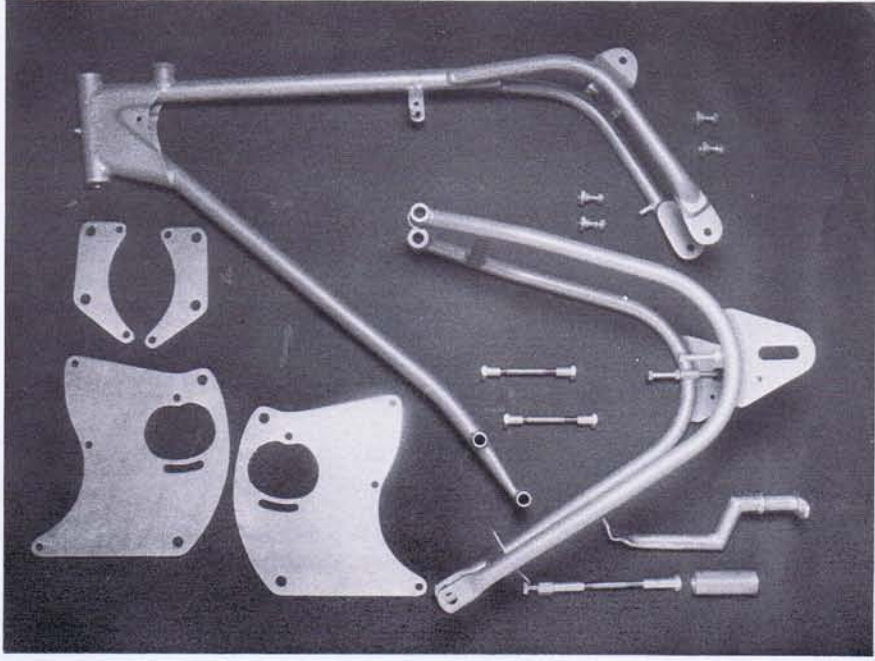

**HAGON SPEEDWAY FRAME ASSEMBLY**

Comprising - Main diamond, rear end, front & rear motor plates, forks, high tensile bolts & nuts.

For centre carb. engines **REF. 511**

1. Fork "H" piece. **REF. 503**
2. Inner legs. **REF. 504**
3. Gaiters. **REF. 505**
4. Springs. **REF. 506**
6. Spring top retainer and nut. **REF. 507**
7. Handle bar clamps. **REF. 508**
8. Head nut and bolt. **REF. 509**
9. Hardened head spindle (extra)  
STD = .867"  
+1 = .874"  
+2 = .881"  
**REF. 510**



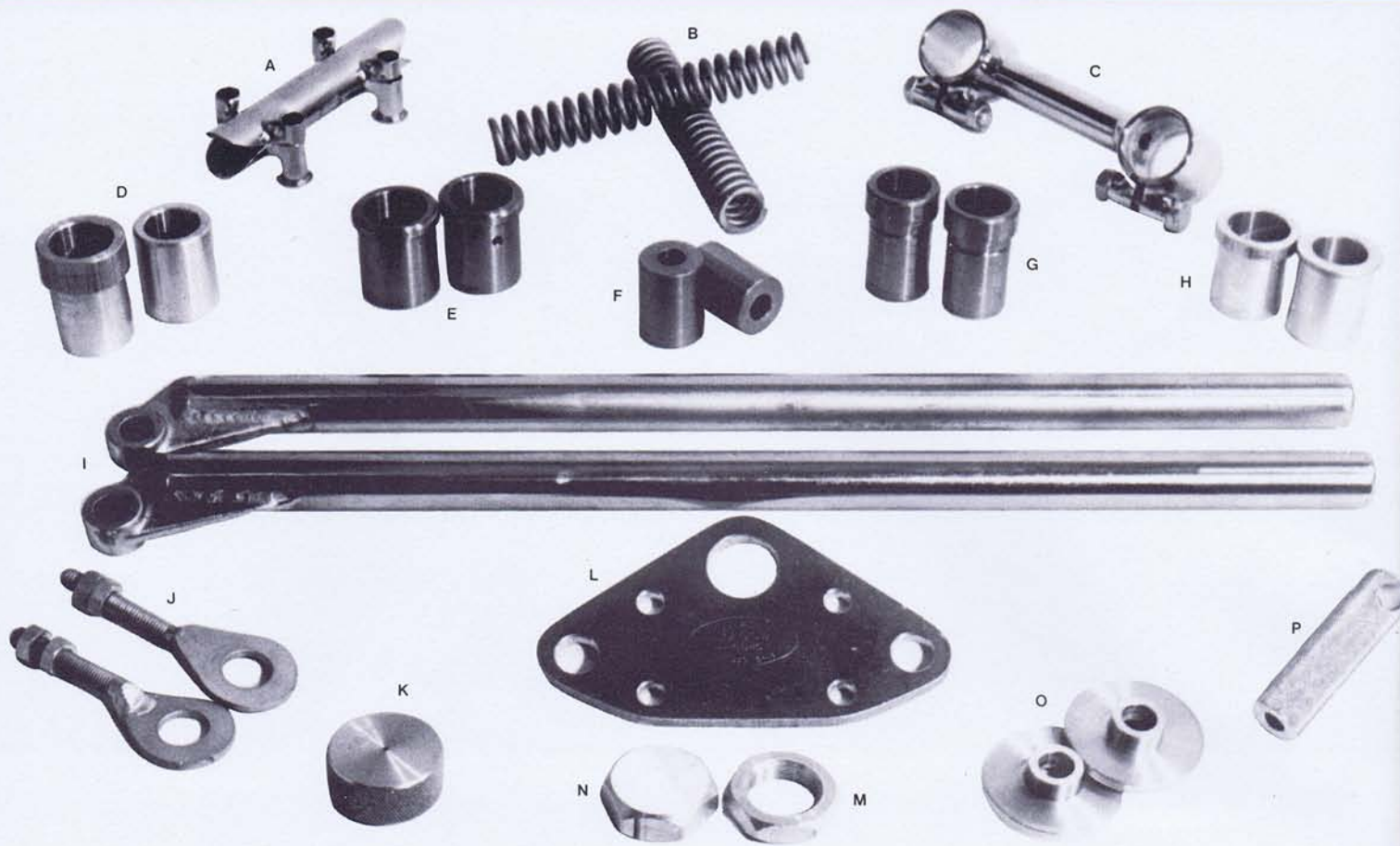

- 6A. **SAFETY HANDLEBAR CLAMPS** greatly reduce the risk of handlebar fracture, recommended for alloy bars.
- 6B. **JAWA FORK SPRINGS** suit all Jawa speedway bikes. Pair
- 6C. **JAWA FORK BRACE** prevents fork flex.
- 6D. **STEERING HEAD BUSH SET** for Hagon forks fitted to Jawa frame. Pair

- 6E. **STEERING HEAD BUSH SET** for Jawa speedway machines. Pair
- 6F. **JAWA FORK BUSHES** in low friction steel upper bush.
- 6G. **JAWA FORK BUSHES** lower bush.
- 6H. **STEERING HEAD BUSH SET** for Jawa forks fitted to Hagon speedway frame.

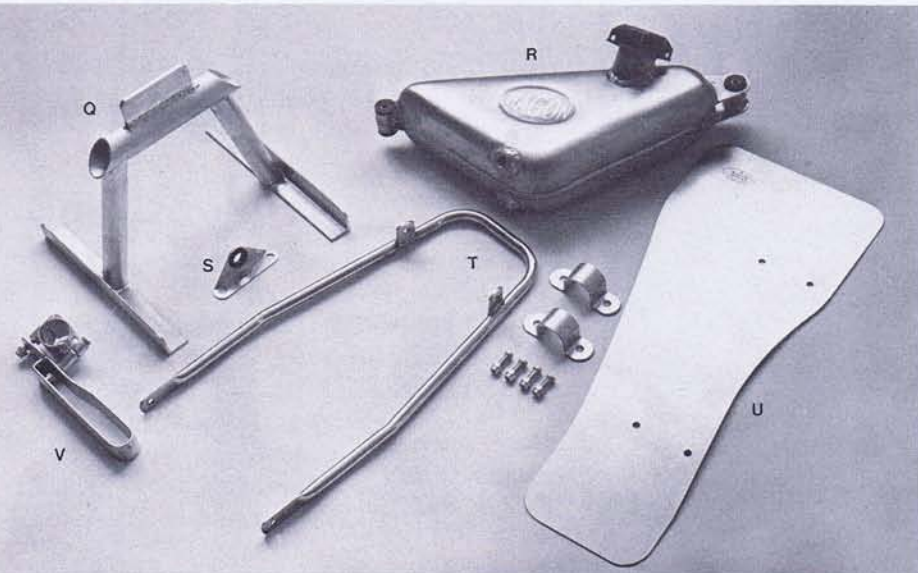

- 6I. **JAWA FORK LEGS** genuine Jawa parts.
- 6J. **JAWA REAR WHEEL ADJUSTERS**
- 6K. **JAWA ALLOY OIL CAP**
- 6L. **JAWA ALLOY FORK CROWN**
- 6M. **JAWA ALLOY STEERING PIVOT NUT**
- 6N. **JAWA ALLOY STEERING PIVOT LOCKNUT**
- 6O. **JAWA FRONT WHEEL BEARING CAP**
- 6P. **SPEEDWAY FOOTREST KNURLED ALLOY** with 3/8" BSF or 10mm thread.
- 6Q. **BIKE STANDS** strong welded construction for speedway and grass bikes.
- 6R. **ALLOY FUEL TANKS** twin fuel outlets. Speedway type for 10mm or 1/4 BSP taps. Grass track type 1/4 BSP.
- 6S. **CABLE TIDY** helps prevent breakage and accident.
- 6T. **SPEEDWAY LIFTING HANDLE** chrome plated.
- 6U. **ALLOY DIRTSHIELD** with fixing brackets.
- 6V. **UNIVERSAL CHAINGUIDE** 1 1/4" split clamp fitting keeps chains on sprockets.



**PLASTIC CHAINGUARD**

High impact plastic chainguard fits almost all speedway and grass bikes. Covers both chain runs. Quickly and easily removed for sprocket changes complete with fixing brackets. **REF. 6W**

## OFFICIAL DISTRIBUTORS WESLAKE AND JAP ENGINES AND SPARE PARTS

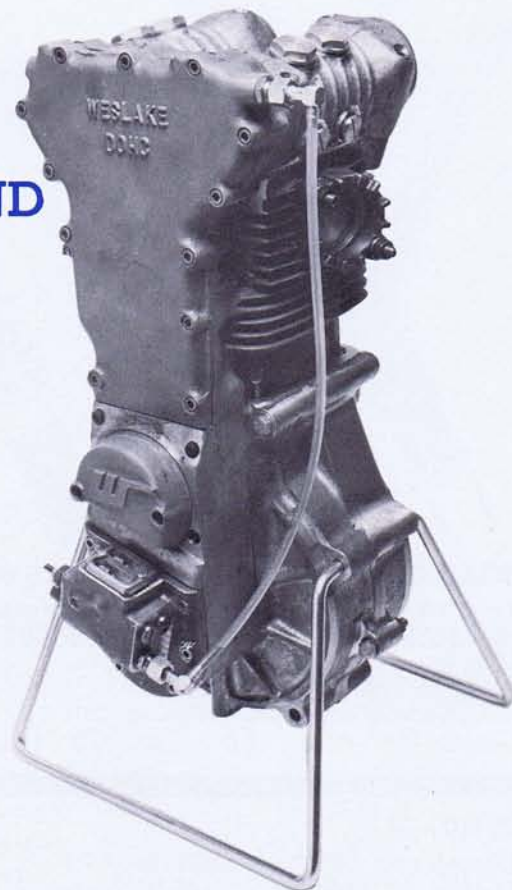
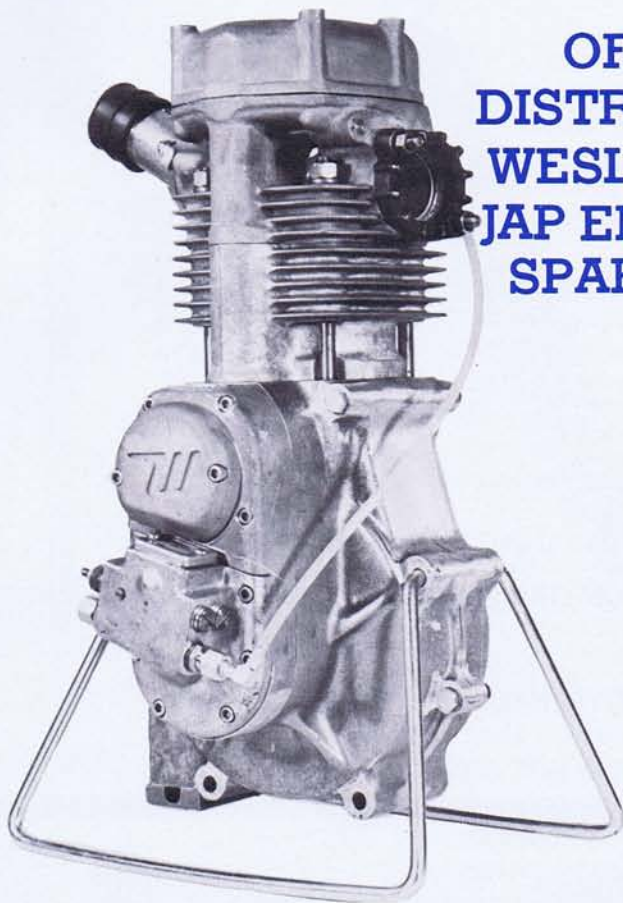

### WESLAKE ENGINES

- 500cc DOHC REF. 701
- 500cc SOHC REF. 702
- 500cc SPEEDWAY OHV REF. 703
- 500cc LONG TRACK OHV REF. 704
- 500cc 2 VALVE REF. 705
- 350cc DOHC REF. 706
- 350cc GRASS TRACK OHV REF. 707
- 350cc SOHC REF. 708

### JAP ENGINES

- 500cc DOHC 4 Valve REF. 709
- 500cc TYPE 84S REF. 710
- 500cc TYPE 4B REF. 711
- 350cc GRASS TRACK REF. 712

### RACING ENGINES

GODDON GR500-MAICO-BULTACO-HUSQUVARNA-WESLAKE  
TWIN AND ALL OTHER LEADING MAKES SUPPLIED.

### YAMAHA ENGINE CONVERSIONS XS650 To 750cc BIG BORE KIT

More power from the robust Yamaha twin using forged racing pistons of similar weight to the standard components eliminating vibration problems. Compression ratio 9.3:1 this conversion is only suitable for the XS650 engine, not the earlier XS1/XS2 models.  
COMPLETE SET PISTONS 80mm REF. 713  
Oversize pistons available 80.25mm REF. 714

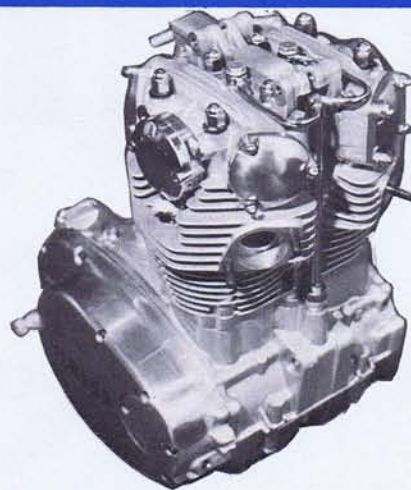

### SUZUKI ENGINE CONVERSIONS

SP370 To 450cc / SP400 To 480cc

By modifying your flywheels, crankcase and cam chain we can achieve a stroke increase gaining an extra swept volume of 80cc and a substantial power increase. This modification is fully race proven for reliability and performance. The original con rod and big end are retained and all necessary parts are provided. REF. 715

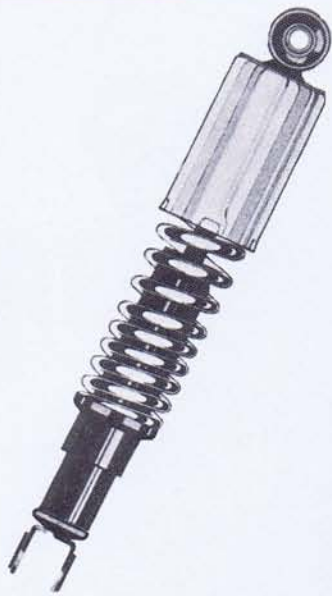

### ROAD GAS SHOCK

Yoke fitting.  
Pair. **REF. 801**



### ROAD GAS SHOCK

Honda twin yoke.  
Pair. **REF. 802**



### COMPETITION GAS SHOCK

Pair.  
**REF. 803**



### COMPETITION GAS SHOCK

Twin spring.  
Pair. **REF. 804**

### ROAD GAS DAMPERS

Soft, Medium and Hard damping rates.  
Lengths 11.9", 12.4", 12.9", 13.4", 13.9". Pair. **REF. 805**

### COMPETITION GAS DAMPERS

Soft, Medium and Hard damping rates.  
Lengths 11.8", 12.8", 13.0", 13.4", 14.3", 15.0". Pair. **REF. 806**

### SPRINGS

Mono Rate 42lb/in to 210lb/in  
Multi Rate 60/90lb/in or 70/100lb/in  
Twin Rate 53/75lb/in to 96/210lb/in

Most Springs are available in a choice of black enamel or polished chrome.

### MOUNTING BUSHES

8, 10, 12, 14, 16mm  
5/16", 3/8", 7/16", 1/2".

Special yoke end fitting are available for most Honda and Suzuki models.

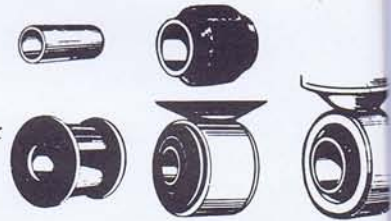

### ADJUSTER SPANNER

For Road Gas Shocks.  
**REF. 807**



### SPRING IDENTIFICATION CHART

Suspension Springs in order of Spring Rate										
Rate lb/in.	Spring Part No.	Colour Code	Free Length	Minimum Working Length	Solid Length	Normal fitted Length	Normal fitted Load	Spring Code		
42	64539002	White/Yellow	9.83	4.00	3.50	9.4	18	42WY94		
45	9054-64	White/Blue	8.78	3.60	3.18	8.0	35	45WB86		
54	9054-90	Yellow/Blue	9.77	4.00	3.83	9.4	20	54YB94		
60-90	64541820*	Green/Orange	9.20	4.09	4.13	8.1	100	90GO81		
60-90	64541788*	Green/Purple	8.66	4.25	4.13	8.0	60	90GP80		
70-100	64541530*	Green/Pink	9.10	4.70	4.70	8.4	70	100GP81		
70-100	64543626*	Green/Pink	9.10	4.70	4.70	8.4	70	100GP81		
75	9054-317	Yellow/Yellow	9.53	4.20	4.12	8.0	40	75YY80		
75	64545134*	Yellow/Yellow	8.53	4.20	4.12	8.0	40	75YY80		
78	9054-66	Yellow/Green	9.69	4.00	3.97	9.4	23	78YG94		
80	9054-103	Yellow/Red	7.80	3.60	3.42	7.5	23	80YR75		
88	9054-59	Yellow/White	8.71	3.60	3.59	8.4	28	88YW84		
88	64543501*	Yellow/Orange	9.49	5.52	5.52	8.4	96	88YO84		
90	9054-94	Green/White	9.70	4.50	4.42	9.4	27	90GW94		
90	64543735*	Green/White	9.70	4.50	4.42	9.4	27	90GW94		
90	9054-58	Green/Yellow	9.70	3.60	3.53	8.0	27	90GY80		
96	64543819	Green/Red	8.30	3.60	3.59	8.1	27	96GR81		
100	9054-280	Green/Green	8.68	4.00	3.96	8.4	28	100GG84		
100	64543708*	Green/Green	8.68	4.00	3.96	8.4	28	100GG84		
100	9054-53	Green/Blue	7.70	3.60	3.21	7.4	30	100GB74		
110	9054-312	Red/Pink	8.03	4.00	3.83	7.8	25	110RP78		
110	9054-277	Red/Red	8.32	3.60	3.57	8.0	35	110RR80		
110	9054-88	Red/White	9.65	4.50	4.48	9.4	28	110RW94		
110	64544235*	Red/White	9.65	4.50	4.48	9.4	28	110RW94		
110	64532786	Red/Blue	8.81	4.40	4.32	8.4	45	110RB84		
110	64544754*	Red/Blue	8.81	4.40	4.32	8.4	45	110RB84		
120	64543817*	Red/Green	8.03	4.70	4.14	7.5	63	120RG75		
126	9054-63	Red/Yellow	8.80	4.00	3.97	8.4	50	126RY84		
126	64544621*	Red/Yellow	8.80	4.00	3.97	8.4	50	126RY84		
132	64539963	Red/Orange	8.47	4.30	-	8.0	62	132RO80		
132	64543764*	Red/Orange	8.47	4.30	4.17	8.0	62	132RO80		
145	64543818	Blue/Yellow	8.19	4.20	4.11	8.0	28	145BY80		
145	64544234*	Blue/Yellow	8.19	4.20	4.11	8.0	28	145BY80		
150	64543820	Blue/Pink	8.88	4.85	4.85	8.4	73	150BP84		
160	9054-165	Blue/Green	7.26	3.60	3.48	7.0	42	160BG70		
195	64540471	Blue/White	9.59	5.83	-	9.4	35	195BW94		
210	64541653	Blue/Orange	8.97	5.40	4.68	8.8	35	210BO88		

\* Twin Rate Spring

### SPRING COMPRESSOR TOOL

Designed and manufactured by us to fit all Open Spring Suspension Units with Springs of Right or Left Hand Coils even the strongest Springs can be fitted easily and safely without assistance. **REF. 808**





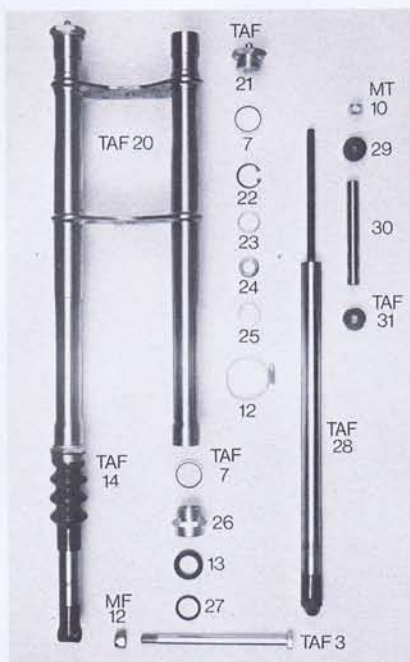

**HAGON AIR FORKS**

- Pneumatic Suspension
- Constant Volume 2-Way Damping
- Lightweight
- Can be fitted to most Grass/Long Track Bikes

**SPECIFICATION:-**

Overall Length	73.4cm (2'4 7/8")
Distance between crowns	15.2cm (6")
Distance between legs	11.4cm (4 1/2")
Weight	4.25kg. (9.35lb)
Movement	12.1cm (4 3/4")
Spindle Diameter	12mm

COMPLETE HAGON AIR FORKS REF.901

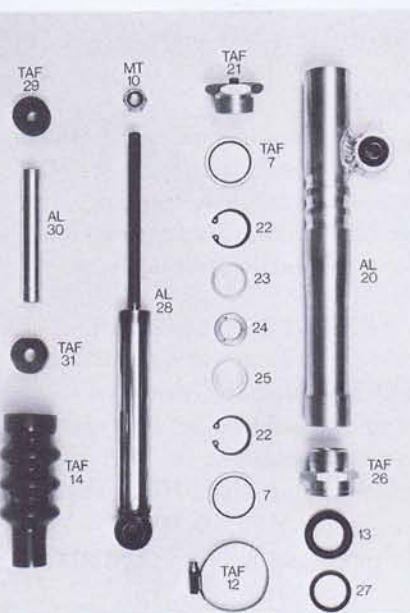

**HAGON AIR SHOCKS**

Hagon air shocks are the rear suspension counterparts of Hagon air forks and many components are common to both. They also share the same virtues of very low weight and 2-way damping.

**SPECIFICATION**

Overall Length	435mm
Mounting Centres	
Extended	345mm
Compressed	250mm
Weight	1.6kg.

COMPLETE HAGON AIR SHOCKS PAIR REF.902



**HAGON FORKS**

GRASS TRACK VERSION. Overall length 28". Distance between crowns 6". Will accept up to 23" wheel. Distance between fork blades 4 1/2". Movement 4". Weight 12 3/4 lbs. Suspension by rubber with hydraulic damper. Lubrication by grease nipples. Finish, Blue stoved enamel and Cadmium plated fittings. Supplied complete with handlebar clamps, and damper. WHEN FITTING FORKS TO FRAME ENSURE THAT SPINDLE BOLT IS TIGHT OTHERWISE HOLE IN FORK CROWN WILL BECOME WORN. IN THE EVENT OF DAMAGE RETURN 'H' PIECE AND BOTH INNER LEGS TO WORKS FOR REPAIR.

The hardened Head Spindle is available in sizes:-  
 STANDARD = 0.867", +1 = 0.874 0, +2 = 0.881" HF-08  
**MAINTENANCE.** Before lubricating it is essential to remove rubber bands and 'bottom' the forks, then apply 4-6 strokes of grease gun, containing engine oil. DO NOT USE GREASE.

FORKS COMPLETE REF.903

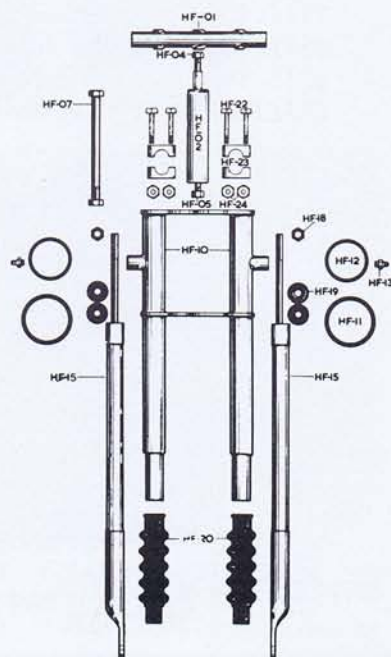

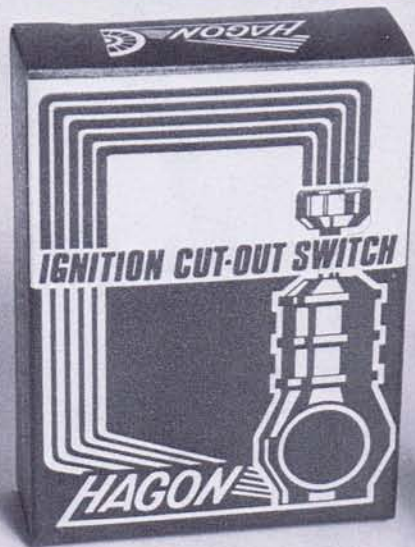

### HAGON IGNITION CUT OUT SWITCH

Lightweight, rugged and reliable. Black nylon body, silver contacts supplied with spare toggle, connectors and instructions suitable for all ignition systems. **REF. 1001**

### T.R.C. IGNITION PACK

This rechargeable ignition system has an on/off switch and running/charging indicators. It is suitable for all speedway grass and long track engines supplied complete with charging and running leads (extra long for cut out) instructions and 6 month guarantee. **REF. 1002**

### LUCAS POWER COILS

compact powerful ignition coils supplied with bracket and connectors.

6 volt coil **REF. 1003**

12 volt coil **REF. 1004**



### CHAMPION PLUGS

Racing and gold paladium types long and short reach 14, 12 & 10mm Road/Warm up plugs **REF. 1005**  
Racing types **REF. 1006**  
Gold paladium types **REF. 1007**



### NGK PLUGS

Road and Race types 14, 12 & 10mm  
Racing types **REF. 1008**  
Road types **REF. 1009**



**BATTERY 6v (6N6 3B)** ideal battery size for coil ignition. **REF. 1010**



### WATERPROOF PLUG CAPS

Straight type **REF. 1011**  
90° type **REF. 1012**



**FAST ACTION 90° TWIST GRIP**  
Die cast alloy construction, 7/8" fitting. **REF. 1101**



**NYLON Q.A. TWIST GRIP**  
7/8" fitting. **REF. 1107**

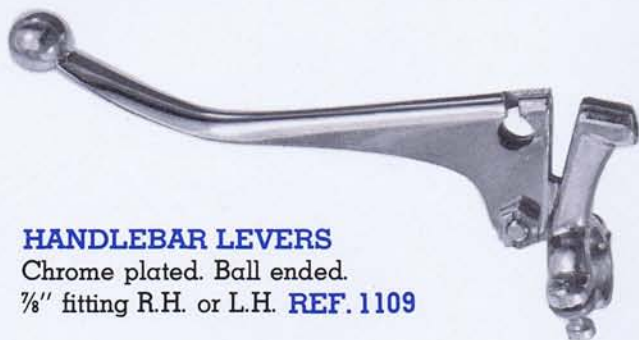

**HANDLEBAR LEVERS**  
Chrome plated. Ball ended.  
7/8" fitting R.H. or L.H. **REF. 1109**



**ALLOY HANDLEBAR LEVERS**  
Dog-leg shape alloy levers  
with fingertip cable adjuster.  
PAIR. **REF. 1121**



**GEARCHANGE/DECOMPRESSOR LEVER**  
Chrome plated, ball ended 7/8" fitting. **REF. 1122**



**RENTHAL ALLOY BARS**

available in a variety of anodized colours and polished alloy.

IVAN MAUGER	Pattern Coloured	<b>REF. 1102</b>
IVAN MAUGER	Pattern Polished	<b>REF. 1103</b>
OLE OLSON	Pattern Coloured	<b>REF. 1104</b>
OLE OLSON	Pattern Polished	<b>REF. 1105</b>
GRASS TRACK	Pattern Polished	<b>REF. 1106</b>



**HIGH TENSILE STEEL HANDLEBAR**  
Hagon grass track pattern. T45 Tubing. **REF. 1108**



**NYLON LINED CONTROL CABLES**

Front brake	Universal	<b>REF. 1110</b>
Throttle	Universal	<b>REF. 1111</b>
Throttle	Dellorto	<b>REF. 1112</b>
Throttle	Amal MkI	<b>REF. 1113</b>
Throttle	Amal MkII	<b>REF. 1114</b>
Clutch	Universal	<b>REF. 1115</b>
Clutch	Norton	<b>REF. 1116</b>
Clutch	Jawa (English lever)	<b>REF. 1117</b>
Clutch	Jawa (Jawa lever)	<b>REF. 1118</b>
Rear brake	(Foot operated)	<b>REF. 1119</b>
Rear brake	(Hand operated)	<b>REF. 1120</b>



**HAND PROTECTORS SETS**

High impact plastic, RED, YELLOW, or BLACK 7/8" fitting, fully adjustable. PAIR **REF. 1123**



**HAGON FIBREGLASS**

- SPOILERS 22" and 19" glitter. REF. 1201
- SPOILERS 22" and 19" union jack. REF. 1202
- CURVED DIRTSHIELDS white. REF. 1203
- CURVED DIRTSHIELDS glitter. REF. 1204
- CURVED DIRTSHIELDS union jack. REF. 1205
- CURVED NUMBER PLATES (white, blue or gold) REF. 1206
- SPEEDWAY MUDGUARDS front glitter. REF. 1207
- SPEEDWAY MUDGUARDS front union jack. REF. 1208
- SPEEDWAY MUDGUARDS Rear glitter. REF. 1209
- SPEEDWAY MUDGUARDS Rear union jack. REF. 1210
- GRASS TRACK MUDGUARD Front glitter. REF. 1211
- GRASS TRACK MUDGUARDS Front union jack. REF. 1212
- GRASS TRACK MUDGUARDS Front white. REF. 1213
- GRASS TRACK MUDGUARDS Rear glitter. REF. 1214
- GRASS TRACK MUDGUARDS Rear union jack. REF. 1215
- GRASS TRACK MUDGUARDS Rear white. REF. 1216



**HAGON SEATS**

LONG SPEEDWAY SEAT REF. 1217

GRASS TRACK SEAT REF. 1218

SHORT SPEEDWAY SEAT REF. 1219

LONG GRASS TRACK SEAT REF. 1220



**HAGON RACING LEATHERS**

The most supple hardwearing hides available are used in manufacturing Hagon brand leathers. Double thickness leather and fully padded at all contact points. Extra strong lining. Guaranteed zips. All suits are made to measure with your own design and colours.

Basic Prices **ADULT SIZES REF. 1301** **JUNIOR SIZES REF. 1302**



**ASHMAN SPEEDWAY BOOTS**

Available in Red and Yellow, or Blue and White sizes 6-11.

**REF. 1303**



**RACING GLOVES**

Leather Racing Gloves with Padded Backs. Various colours.

Junior **REF. 1304** Adult **REF. 1305**

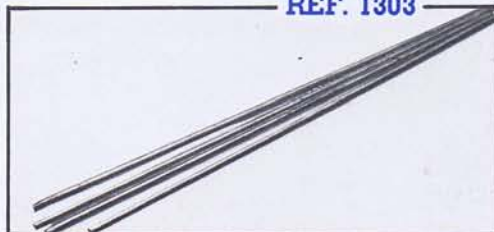

**COLMONOY**

Hard surfacing alloy for steel shoes. Hard wearing. Approx. 2 sticks will re-coat a steel shoe.

Per Stick **REF. 1306**  
Per 500 grammes **REF. 1307**



**HAGON SILVER SHOE**

for DAYTONA and ASHMAN Speedway Boots. Fully colmonoy coated sole. Nickel plated. Custom made steel shoes can be made to fit any boot. Each one fully colmonoy coated. **REF. 1308**



**HAGON TEE-SHIRT**

Junior and adult. Small, Medium & Large. **REF. 1309**



**MONKEY MASK**

Face Mask/Goggles **REF. 1310**

Spare lenses plain or tinted **REF. 1311**



**BACK PROTECTOR**

Hard foam plastic helps protect back and spine from injury, yet can be work under close-fitting leathers. **REF. 1312**



**SPROCKETS.** All HAGON sprockets are made from a very hardwearing and durable alloy. Blanks can be machined to your sample or drawing.

- DURAL  $\frac{5}{8}$ " x  $\frac{1}{4}$ " blank 28-39 teeth **REF. 1401**
- DURAL  $\frac{5}{8}$ " x  $\frac{1}{4}$ " blank 40-53 teeth **REF. 1402**
- DURAL  $\frac{5}{8}$ " x  $\frac{1}{4}$ " blank 54-62 teeth **REF. 1403**
- DURAL  $\frac{5}{8}$ " x  $\frac{1}{4}$ " Jawa 55-62 teeth **REF. 1404**
- DURAL  $\frac{5}{8}$ " x  $\frac{1}{4}$ " Jap 36-53 teeth **REF. 1405**
- DURAL  $\frac{5}{8}$ " x  $\frac{1}{4}$ " Jap 54-62 teeth **REF. 1406**
- STEEL  $\frac{5}{8}$ " x  $\frac{1}{4}$ " Jap 47-52 teeth **REF. 1407**
- DURAL  $\frac{1}{2}$ " x  $\frac{5}{16}$  blank 56-66 teeth **REF. 1408**
- STEEL  $\frac{1}{2}$ " x  $\frac{5}{16}$  Jap 56-64 teeth **REF. 1409**

**ENGINE SPROCKETS** for Weslake, Jawa and Jap 15-21 teeth **REF. 1410**

**RENOLD CHAINS** dominate every type of motorcycle sport. Available cut to any length. (Please state number of pitches required). Also in 25 feet coils.

- RENOLD  $\frac{1}{2}$ " x  $\frac{5}{16}$ " chain per foot **REF. 1411** 25 ft. coil **REF. 1416**
- RENOLD  $\frac{5}{8}$ " x  $\frac{1}{4}$ " chain per foot **REF. 1412** 25ft. coil **REF. 1417**
- RENOLD  $\frac{5}{8}$ " x  $\frac{3}{8}$ " chain per foot **REF. 1413** 25ft. coil **REF. 1418**
- Spring Link **REF. 1414** Cranked Link **REF. 1415**

**RENOLD GRAND PRIX**

25% stronger than other chain. Ultra heavy duty.

- GRAND PRIX  $\frac{5}{8}$ " x  $\frac{3}{8}$ " per foot **REF. 1419**
- GRAND PRIX  $\frac{5}{8}$ " x  $\frac{3}{8}$ " 25ft. coil **REF. 1420**
- GRAND PRIX  $\frac{5}{8}$ " x  $\frac{3}{8}$ " Spring Link **REF. 1421**
- GRAND PRIX  $\frac{5}{8}$ " x  $\frac{3}{8}$ " Cranked Link **REF. 1422**
- GRAND PRIX  $\frac{5}{8}$ " x  $\frac{1}{4}$ " per foot **REF. 1423**
- GRAND PRIX  $\frac{5}{8}$ " x  $\frac{1}{4}$ " 25ft. coil **REF. 1424**
- GRAND PRIX  $\frac{5}{8}$ " x  $\frac{1}{4}$ " Spring Link **REF. 1425**
- GRAND PRIX  $\frac{5}{8}$ " x  $\frac{1}{4}$ " Cranked Link **REF. 1426**

**CHAIN LINK EXTRACTOR** **REF. 1427**



## JAWA COUNTERSHAFT

Supplied complete with sprocket and clutch nut



REF. 1501

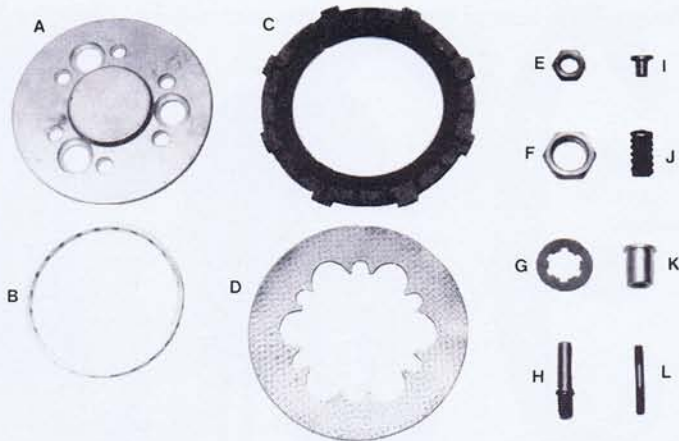

## AMC CLUTCH PARTS

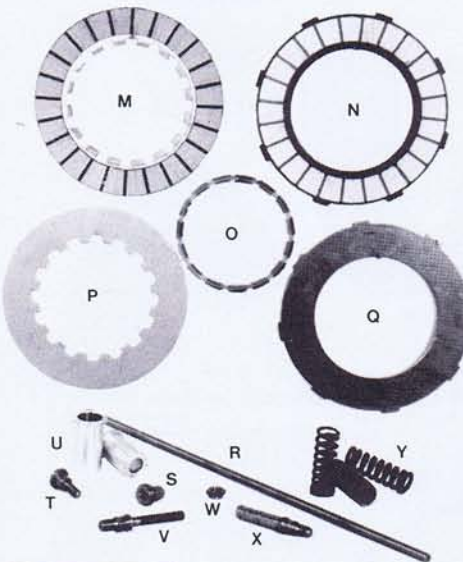

- 15M Bonded Plate
- 15N Bonded Plate
- 15O Clutch Plate
- 15P Steel Plate
- 15Q Steel Plate
- 15R Push Rod
- 15S Spring Adjuster
- 15T Spring Adjuster
- 15U Spring Cup
- 15V Spring Stud
- 15W Spring Stud Nut
- 15X Spring Stud
- 15Y Extra Strong Springs

## JAWA CLUTCH

- 15A Pressure plate
- 15B Clutch Bearing
- 15C Friction Plate
- 15D Steel Plate
- 15E Clutch Nut Small
- 15F Clutch Nut Large
- 15G Lockwasher
- 15H Drive Stud
- 15I Spring Adjuster
- 15J Spring
- 15K Spring Cup
- 15L Spring Stud



## JAWA TYPE CLUTCH

Top quality clutches for JAWA Spline REF. 1502  
For BEWLEY/AMC/NORTON Spline REF. 1503

## NORTON-AMC PARTS

- 16T 5/8 x 1/4 Sprocket REF. 1504
- 14T 5/8 x 1/4 Sprocket REF. 1505
- Outer Gasket REF. 1506
- Large Bearing REF. 1507
- Small Bearing REF. 1508
- Thin Wire Spring REF. 1509
- Gear Lever REF. 1510
- Sprocket Oil Seal REF. 1511
- Sprocket Nut REF. 1512
- Thick Wire Spring REF. 1513
- Inner Gasket REF. 1514

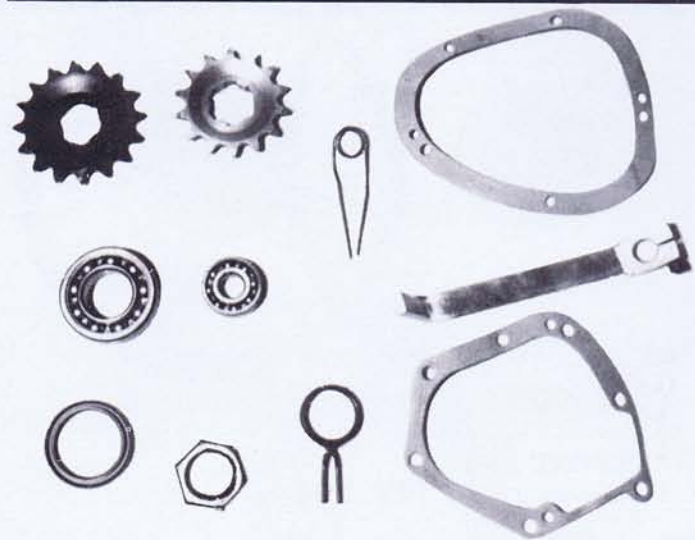

## BEWLEY TWO-SPEED GEARBOX

The Bewley 2 speed gearbox is available in two forms. Footchange and semi-automatic. The semi-automatic is operated by engaging first gear manually, and when second gear is required releasing a handlebar lever, thus enabling the rider to change gear coming out of a bend whilst standing on the footrest. Manual and automatic versions are available with a choice of ratios. 1:44 for tracks of 800 to 1000 metres, or 1:2 for tracks up to 800 metres, also a choice of 14T or 16T gearbox sprocket. All Norton/AMC clutches and Hagon type Norton clutches are suitable. REF. 1515

A special lightweight version is also available with magnesium casings for Automatic boxes. REF. 1516

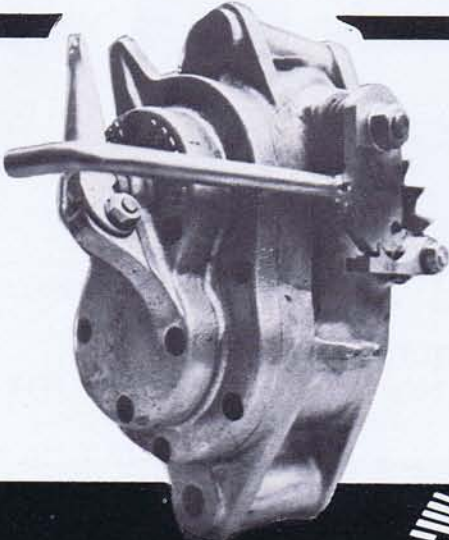

Please state size of tyre to be fitted and number of spoke holes when ordering.



### D.I.D./BORRANI/AKRONT ALLOY RIMS

We hold large stocks of Akront, D.I.D. and Borrani alloy rims with a range of sections for road and sports use.

- Borrani Record **REF. 1601**
- Borrani Cross **REF. 1602**
- Akront Lightweight **REF. 1603**
- Akront Cross **REF. 1604**
- Akront Super **REF. 1605**
- D.I.D. WM0-WM3 **REF. 1606**
- D.I.D. WM4-WM6 **REF. 1607**

16" to 23" WMO to WM6

36 or 40 spoke holes

Drilling extra **REF. 1608**

Any size built to your hub, including rim and rustless spokes. **REF. 1609**

### WHEELBUILDING

Wheelbuilding including spokes (customer's own rim and hub) **REF. 1610**

Spoke sets (36 or 40 rustless spokes and nipples) supplied to pattern or measurements. **REF. 1611**

Chrome spoke and nipple set extra. **REF. 1612**

Postage and packing per wheel boxed.

**REF. 1613**

### CHROME RIMS

Depressed and drilled, available in sizes 16" to 23" WM0 to WM3. 36 or 40 spoke holes. **REF. 1618**  
16" WM5 40 hole rim. **REF. 1619**



### SPOKE KEY

Universal Type **REF. 1614**



Brake drum/disc skimming. **REF. 1615**

### SECURITY BOLTS

Dunlop security bolts WM1, WM2, WM3 **REF. 1616**

### WE REPAIR

Alloy and Magnesium wheels. Honda Comstar, Car Wire, Vintage and Veteran.

### RIM BANDS

Dunlop rim bands

18" and 19"

20" and 21" **REF. 1617**



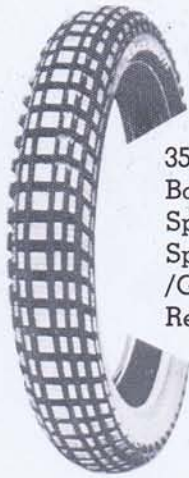

350 x 19  
Barum  
Speedway  
Special  
/Grass  
Rear

REF. 1701



350 x 19  
Barum  
Speedway  
/Grass  
Rear

REF. 1702



350 x 19  
Dunlop  
Speedway  
/Grass  
Rear

REF. 1703



275 x 22  
Barum  
Long Track  
Rear

REF. 1704

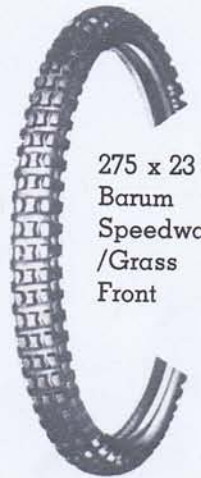

275 x 23  
Barum  
Speedway  
/Grass  
Front

REF. 1705

**INNER TUBES**

(Normal Valve) REF.

- 300/325 x 16" **1709**
- 350 x 16" **1710**
- 225/250 x 17" **1711**
- 300 x 17" **1712**
- 325/350 x 17" **1713**
- 225/250 x 18" **1714**
- 275/300 x 18" **1715**
- 325/350  
/360 x 18" **1716**
- 400/410  
/460 x 18" **1717**
- 275/300 x 19" **1718**
- 325/350  
/360 x 19" **1719**
- 400/410 x 19" **1720**
- 275/300 x 21" **1721**
- 275 x 23" **1722**

**TYRE PRESSURE GAUGE REF.**

- 6-50lb. sq. in. Dunlop Tyre Gauge **1706**
- 2-20lb. sq. in. Dunlop Tyre Gauge **1707**



350 x 19  
Pirelli  
Speedway  
/Grass  
Rear

REF. 1708

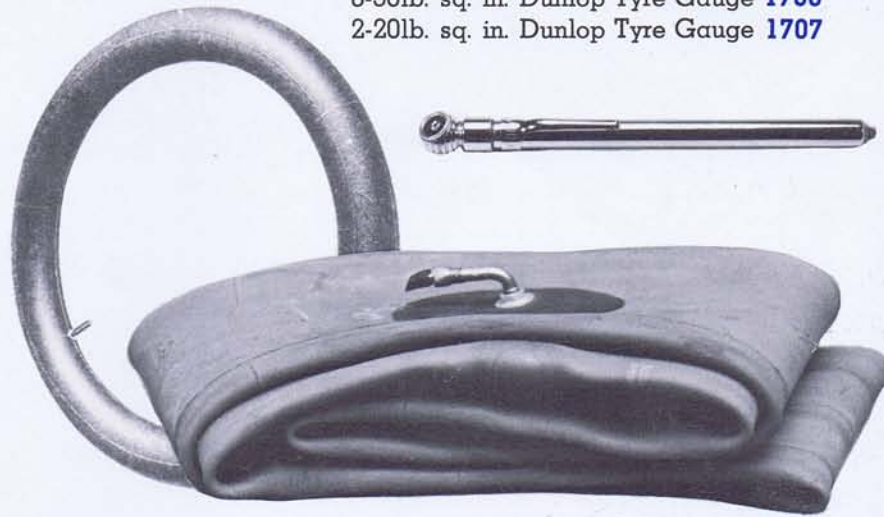

**INNER TUBES (Side Valve) 350 x 19" S.V. REF. 1723 275 x 22" S.V. REF. 1724**

**ROAD TYRES**

**DUNLOP  
TT100-K181**



Semi-Ribbed Front



Rear

**AVON  
ROADRUNNER**



**NEW TT100-K181 SIZE RANGE**

- |                            |                               |
|----------------------------|-------------------------------|
| <b>Semi-ribbed Fronts</b>  | <b>Rears</b>                  |
| 3.60H18 REF. 1725          | 4.10H18 REF. 1730             |
| 4.10H18 REF. 1726          | 4.10H18 Tubeless REF. 1731    |
| 3.60H19 REF. 1727          | 4.25/85H18 REF. 1732          |
| 4.10H19 REF. 1728          | 4.25/85H18 Tubeless REF. 1733 |
| 4.10H19 Tubeless REF. 1729 |                               |

**TT100 K81 SIZE RANGE**

- |                    |
|--------------------|
| 80/90H17 REF. 1734 |
| 80/90H18 REF. 1735 |
| 3.60H18 REF. 1736  |
| 4.10H19 REF. 1737  |

Avon Roadrunners are available in the following sizes.

- |                   |                      |
|-------------------|----------------------|
| 5.10H16 REF. 1738 | 4.10H18 REF. 1743    |
| 3.10H17 REF. 1739 | 4.25/85H18 REF. 1744 |
| 5.10H17 REF. 1740 | 4.70H18 REF. 1745    |
| 3.10H18 REF. 1741 | 3.60H19 REF. 1746    |
| 3.60H18 REF. 1742 | 4.10H19 REF. 1747    |

For machines under 250cc, and rear fitment to certain British bikes, TT100 K81 tyres remain available.

\*Also available in tubeless construction with distinctive colour inner liner for positive identification. It is essential that tubeless tyres are fitted only to suitable rims.



### HAGON CONICAL REAR HUB

Brake	136mm
Weight	3 Kgs
Spindle	17mm
Spoke Holes	40
Overall Width	170mm

REF. 1801

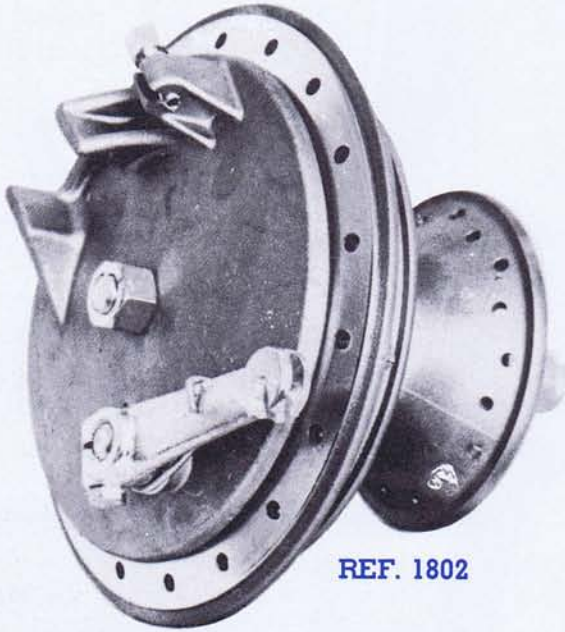
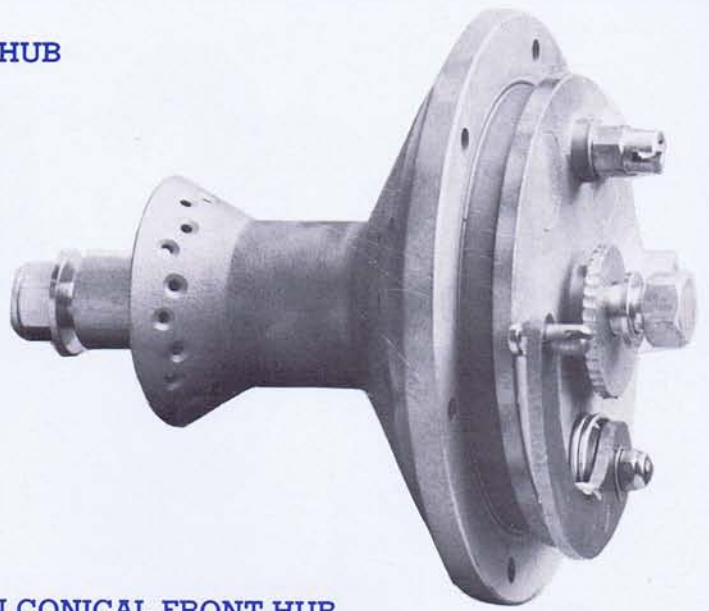

REF. 1802

### HAGON CONICAL FRONT HUB

Powerful	125mm Brake
Weight	2 Kgs
Spindle	12mm
Spoke Holes	36
Overall Width	114mm

Die Case Aluminium alloy with Sealed Long Life Bearings

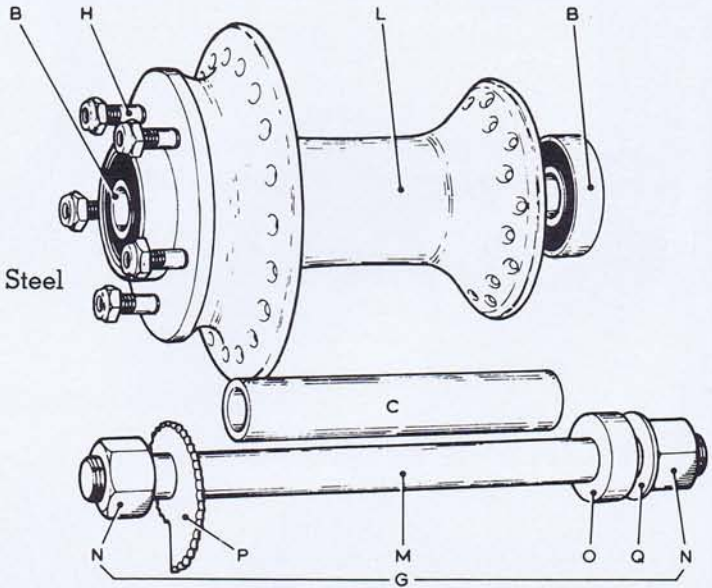

### HAGON MAGNESIUM REAR HUB

Made from Die Cast Electron. 17mm Spindle. 36 Spoke Holes. Sealed Bearings.

#### Complete Assembly

- 18B. 17mm bearings
- 18C. Hardened distance piece
- 18G. 17mm spindle assembly  
(as shown)
- 18H. 11mm STUDS
- 18L. Magnesium hub,  
Complete

#### Spindle Assembly

- 18M. Spindle only 17mm Steel
- 18N. Alloy 17mm Nuts
- 18O. Alloy Spacer
- 18P. Snail Cam - 17mm
- 18Q. Washers 17mm

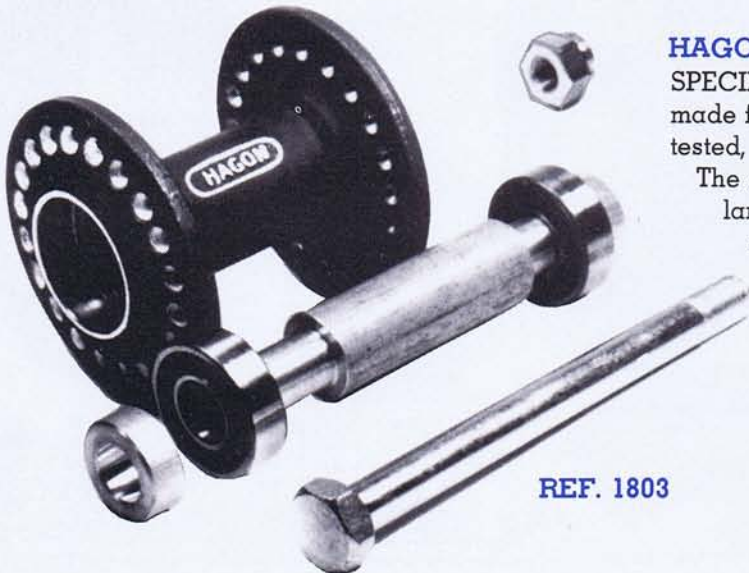

REF. 1803

### HAGON MAGNESIUM FRONT HUB

**SPECIFICATION:** The Hagon Magnesium Front Hub is made from die cast Electron 'C' and is heat treated, crack tested, and chromated. Spindle size 12mm. 36 spoke holes. The centre spacer locates inside the bearing, enabling a larger spindle to be fitted by boring out the centre spacer.

- Magnesium Hub, with bearings and centre spacer.
- Bearings, double rubber sealed. Needs no lubrication.
- Dural centre spacer, 12mm bore.
- Push-on dural spacers, will not fall out when wheel is removed.
- 12mm Spindle and nut.

Weight 370 grams. Also available with 1/2" Spindle.

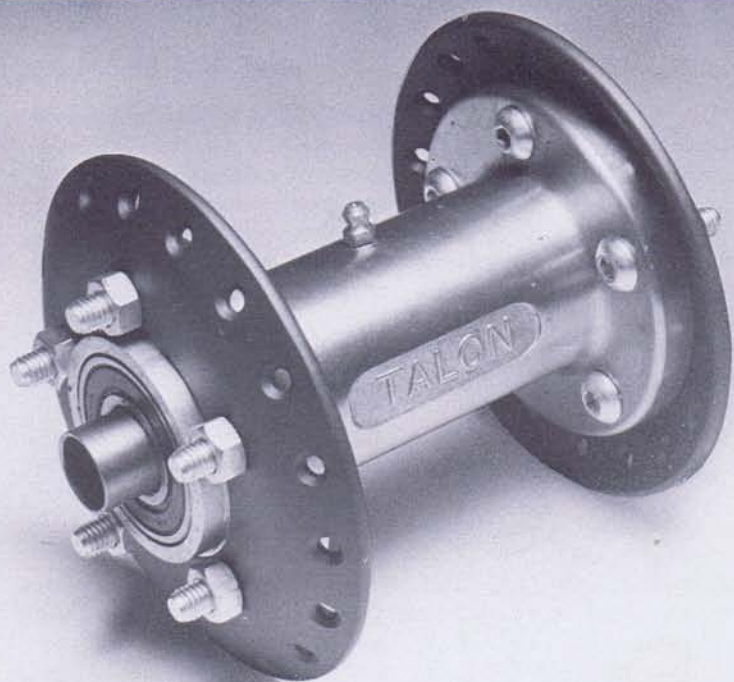

#### TALLON REAR HUB

Double sided hub for speedway or grass track, lightweight alloy with 36 or 40 spoke holes 17mm spindle. Accepts Jawa sprockets. **REF. 1901**

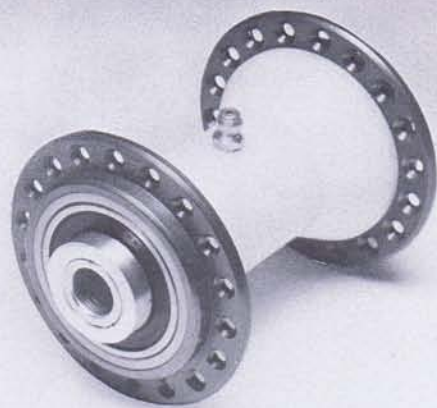

#### TALLON FRONT HUB

Spool hub with nylon body and alloy spoke flanges for very low weight and high strength 12mm spindle. **REF. 1902**

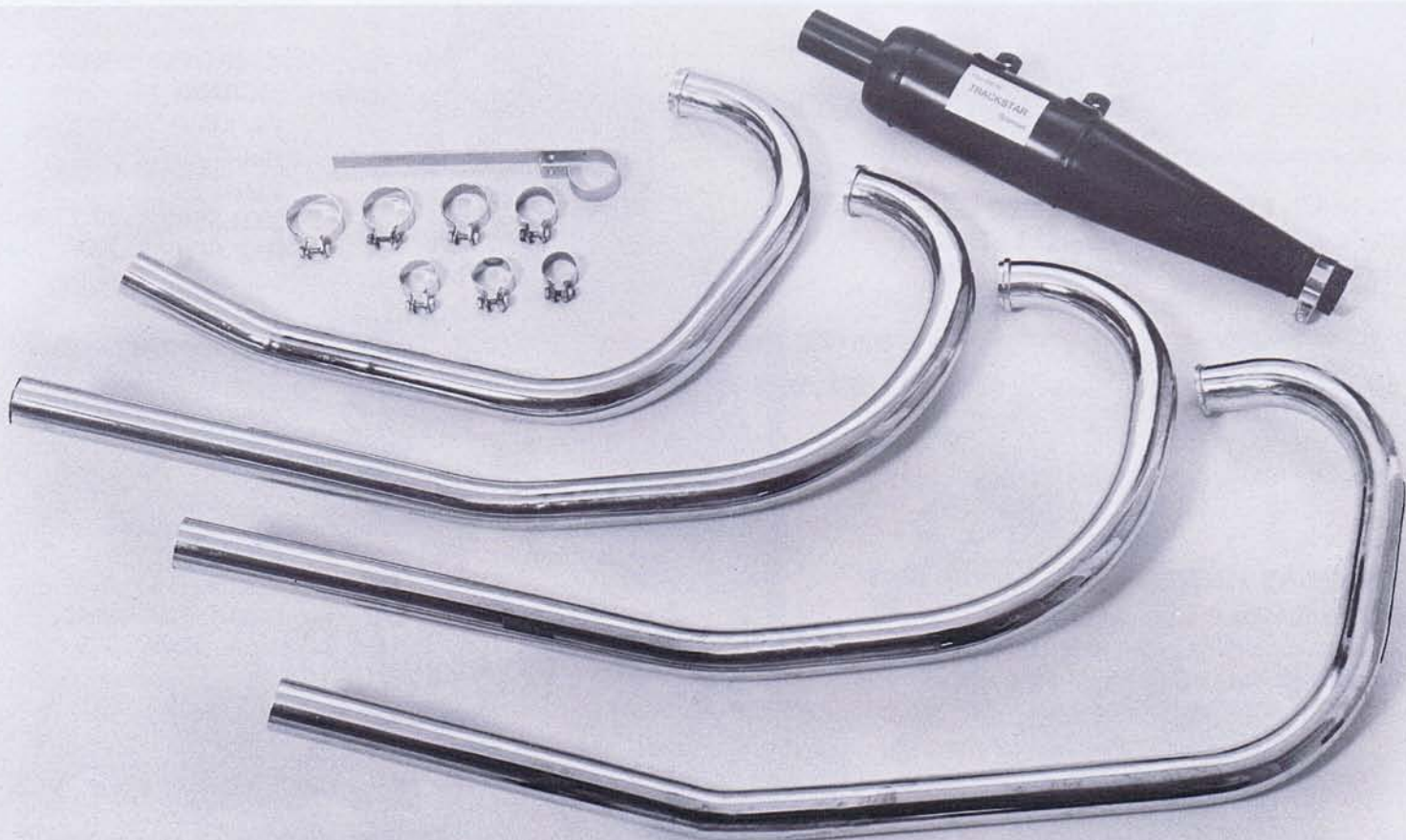

**EXHAUST PIPES** Weslake Chrome Pipe **REF. 1903**  
 Jawa Chrome Pipe **REF. 1904**  
 Jap Chrome Pipe **REF. 1905**

**EXHAUST PIPE CLIPS** chrome plated 1 1/4" to 2" **REF. 1906**

**EXHAUST PIPE BRACKET** for Weslake Jap and Jawa pipes **REF. 1907**

**SILENCERS** Roe Type **REF. 1908**  
 Maximum Type **REF. 1909**  
 Trackstar Type **REF. 1910**  
 Jawa Type **REF. 1911**

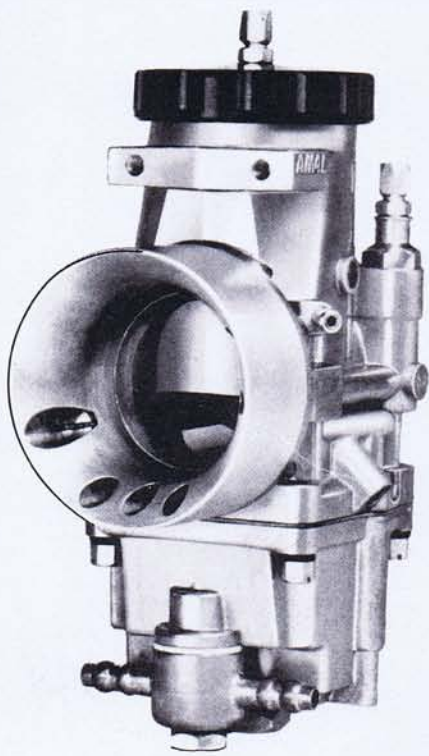

**AMAL  
MK2 CONCENTRIC  
CARBURETTORS**

PETROL or ALCOHOL  
SETTINGS.

2900 SERIES 28, 30, 32, or  
34mm **REF. 2001**

2000 SERIES 36, 38 or  
40mm **REF. 2002**

Please state make, model, cc  
and fuel used when ordering.



**K&N AIR FILTERS** highly efficient washable air  
filter complete with clips suitable for 60-65mm  
diameter carb. inlets **REF. 2005**

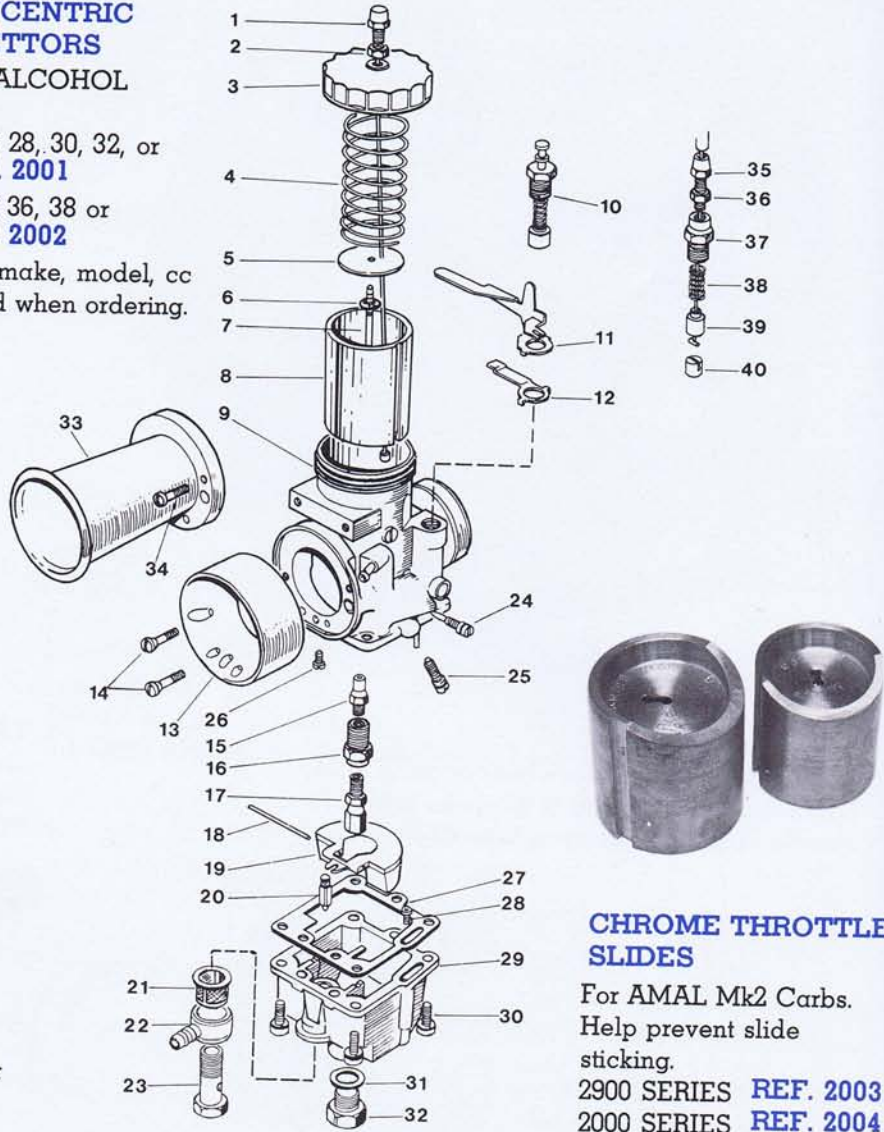

**CHROME THROTTLE  
SLIDES**

For AMAL Mk2 Carbs.  
Help prevent slide  
sticking.

2900 SERIES **REF. 2003**  
2000 SERIES **REF. 2004**



**UNIKE "62"  
SPEEDWAY FILTER**

**REF. 2008**

Specially designed for rapid filter  
changing, spun alloy body, to fit 60-62mm  
supplied with hose and clips in various colours

For "62" filter  
**REF. 2006**



For "45" filter  
**REF. 2007**

**REPLACEMENT FOAM**



**UNIKE "45" FILTER**

Similar to the 62 type but suitable  
for fitting to 40-45mm diameter  
various colours **REF. 2009**



**REF.  
2010**

**UNIKE "204"** one piece foam filter  
mounted on a spring core, air flow  
restriction only .002%. Fits 40-45mm



**UNIKE  
STUBBY FOAM**

Filter bonded to a moulded rubber  
mounting specially short for  
restricted spaces 60-65mm **REF. 2011**

**UNIKE 203  
REF.  
2012**



foam filter similar to  
"Stubby" type but with greater foam area  
to increase intervals between cleaning  
60-65mm

# HAGON for

## AMAL 'POWER JET' CARBURETTERS

The 'power jet' is a variation of the famous Amal Mark 2 Concentric carburetters for two stroke engines, particularly those for competitions, racing, motocross etc. The large bore carburetters used for these purposes usually require an abnormally large main jet for optimum power at maximum rpm. This can produce a rich mixture in the mid-rev range, with loss of power and hesitant performance; fitting the 'power jet' reduces the main jet size and eliminates this problem.

The 'power jet' is located in the carburettor body and discharges through a tube in the upper side of the intake adaptor. This location ensures that air flow into the carburettor is not interrupted.

The 'power jet' size is usually 25% to 30% of the original main jet, and the ratio of 'power jet' to main jet may be adjusted more accurately, within certain limits, by further experimental testing.

Alternatively 'power jet' kits can be purchased for fitting to most existing Amal Mark 2 Concentric carburetters. Each kit contains the appropriate power and main jets. Note that right R and left L handed carburetters require different kits. Each kit contains the following parts: air intake adaptor complete with spray tube, power jet, main jet, 'O' ring and annular ring. Please state size and right or left handed when ordering. Power Jet Kit **REF. 2101**

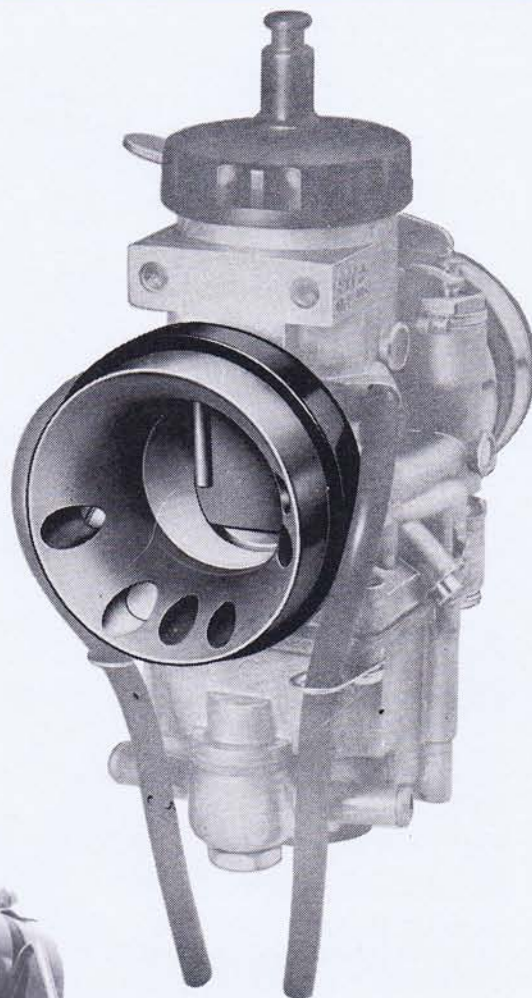

## HAGON TWIN FLOAT CONVERSION KIT

Twin float conversion for Amal concentric Mark 2 carbs.

This precision engineered kit contains everything needed to double the fuel flow and double the bowl capacity of your Amal carburettor. Supplied with full instructions.

**REF. 2102**

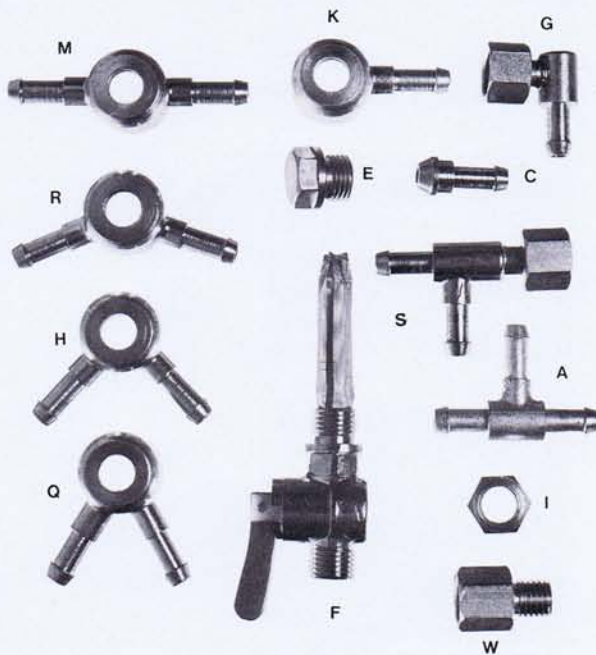
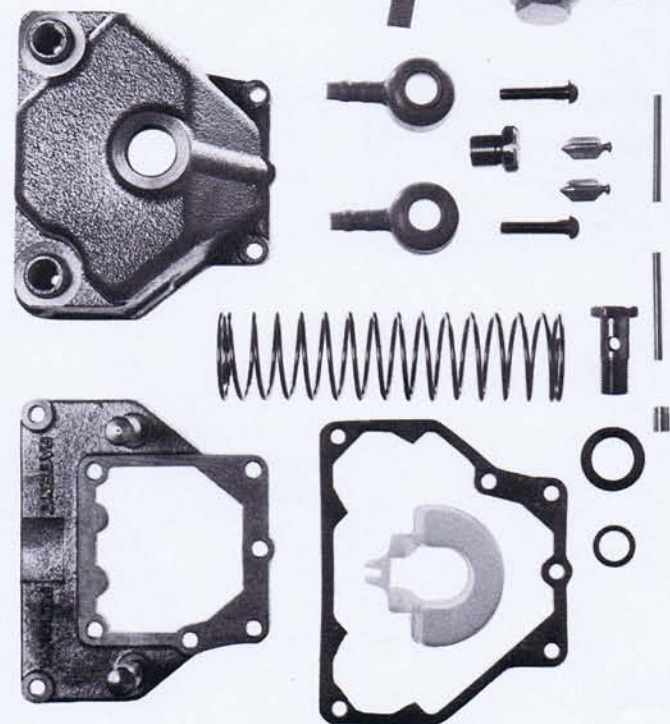

### HAGON FUEL TAPS & CONNECTORS

- |                                |                    |
|--------------------------------|--------------------|
| 21A T Piece                    | 21G 90° Connector  |
| 21C Ferrules, Brass and Alloy. | 21H Twin Feed 90°  |
| 21E Plug.                      | 21K Single Feed    |
| 21F Tap.                       | 21M Twin Feed 180° |
| 21W 10mm/¼ BSP Adaptor         | 21Q Twin Feed 60°  |
| 21I Nut ¼ BSP                  | 21R Twin Feed 150° |



- A. BLACK P.V.C. TAPE. Large roll. REF. 2201
- B. JUMBO rolls super strong RACER TAPE. REF. 2202
- C. UNIVERSAL PULLER SET. REF. 2203
- D. SOLVOL AUTOSOL alloy & chrome polish. REF. 2204
- E. JAWA/WESLAKE CYLINDER BOLT EXTRACTOR. REF. 2205
- F. SPROCKET BODY EXTRACTOR for Jawa. REF. 2206 for Jap. REF. 2207 for Weslake. REF. 2208

- G. JAWA CAM FOLLOWER GUIDE TOOL. REF. 2209
- H. CIRCLIP PLIERS combined internal & external. REF. 2210
- I. JAWA/WESLAKE CYLINDER BOLT SPANNER. REF. 2211
- J. OHV VALVE SPRING COMPRESSOR. REF. 2212
- K. HERMETITE TORQSEAL locking liquid. REF. 2213

## RACING PLATES AND NUMBERS

9" x 11" Oval plastic plates — white, blue, yellow, green  
REF. 2214

Self-adhesive backgrounds 9" x 11" All colours  
REF. 2215

Self-adhesive numerals — white or black REF. 2216

## FUEL AND OIL

Castrol "R" 40	1 Litre Tin	REF. 2221
Castrol "R" 40	5 Litre Tin	REF. 2222
Castrol M	5 Litre Tin	REF. 2223
Methanol	5 Litres	REF. 2224
Methanol (Non Return Can)	25 Litres	REF. 2225
Nitromethane	1 Litre	REF. 2226
Nitromethane	5 Litres	REF. 2227

PLEASE NOTE: Fuel and oil are available to callers only.

## STURDY NYLON TIE ONS

1" wide.  
Quick Fasteners.  
REF. 2228



## BURETTE

For measuring cylinder volumes and compression ratios.  
REF. 2217



## ALLOY TIMING DISC

7" Diameter. Tough. Accurate and easy to use with etched calibrations — a must for serious engine work. REF. 2218

## WORKSHOP ENGINE STANDS

for WESLAKE, JAWA, GODDEN or JAP. REF. 2219

## ENGINE NUT SPANNER

for WESLAKE and JAP. REF. 2220





**PRESTON PETTY UNBREAKABLE GUARDS**

"BAJA" Front Guard

Ideal for muddy grass tracks. REF. 2301

Standard Rear Guard

5 1/4" Wide — 27 3/4" Long. REF. 2302

**HAGON SWINGING FOOTREST**

New type construction for international regulations. REF. 2303

**HAGON FOR**

# Mongoose

## BMX

### The Winners' Choice!

Most Mongoose bikes come in a range of great colours. For availability, see your Mongoose price list.



supergoose



mongoose

Wire wheel freehub model illustrated. Also available as coaster with single gooseneck.



mongoose II

Also available with Skyway Full-nylon wheels.



team mongoose

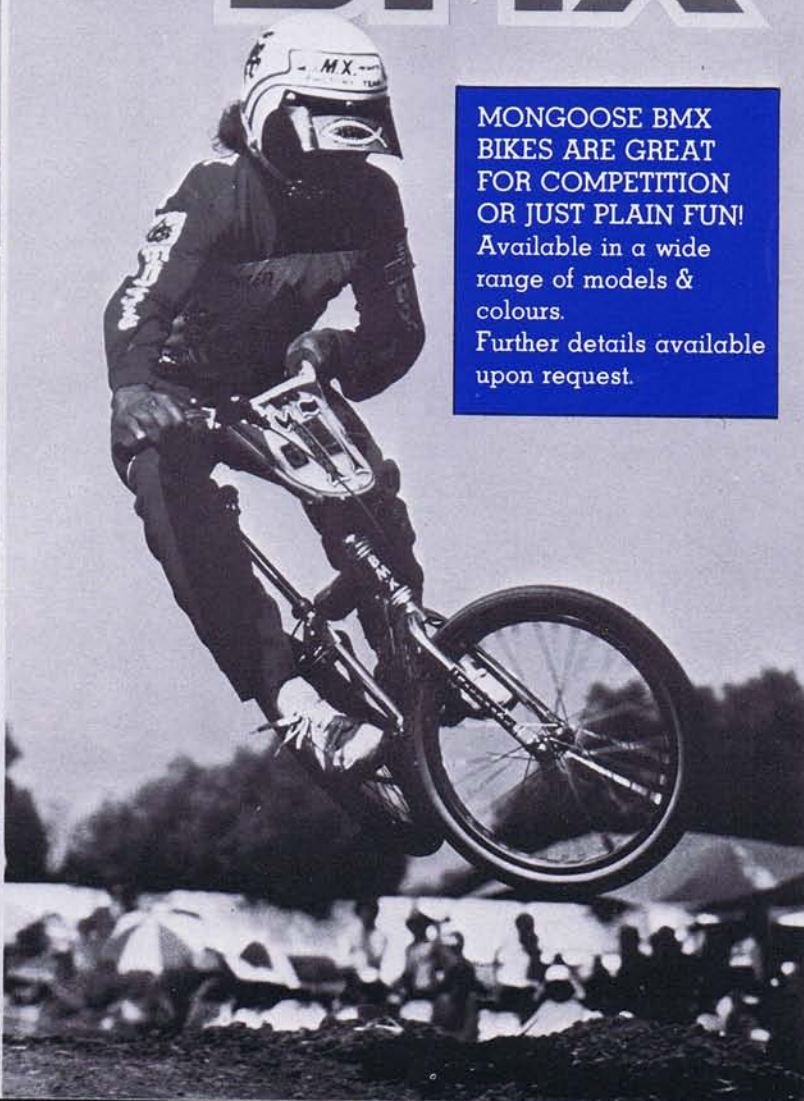

**MONGOOSE BMX BIKES ARE GREAT FOR COMPETITION OR JUST PLAIN FUN!**  
Available in a wide range of models & colours.  
Further details available upon request.



supergoose II



motomag

Freehub model illustrated.

Also available as coaster with single gooseneck.



minigoose

Also available: Team Minigoose.



mitygoose

# Badges



CLOTH BADGE. Ideal for Leathers, Blazers, Overalls etc. REF. 241



REF. 242



REF. 243

SELF-ADHESIVE FLEXIBLE METAL BADGES.



SELF-ADHESIVE PLASTIC BADGE. REF. 244 AS ABOVE BUT 180 x 270 mm REF. 245

